

## Breadboards make it easy to assemble electronic circuits without soldering

The holes on a breadboard are connected as show with the colored lines.  
 The vertical strips on either side of the central gap are connected in groups of five.  
 The horizontal red and blue "bus" lines are connected all the way across the board.

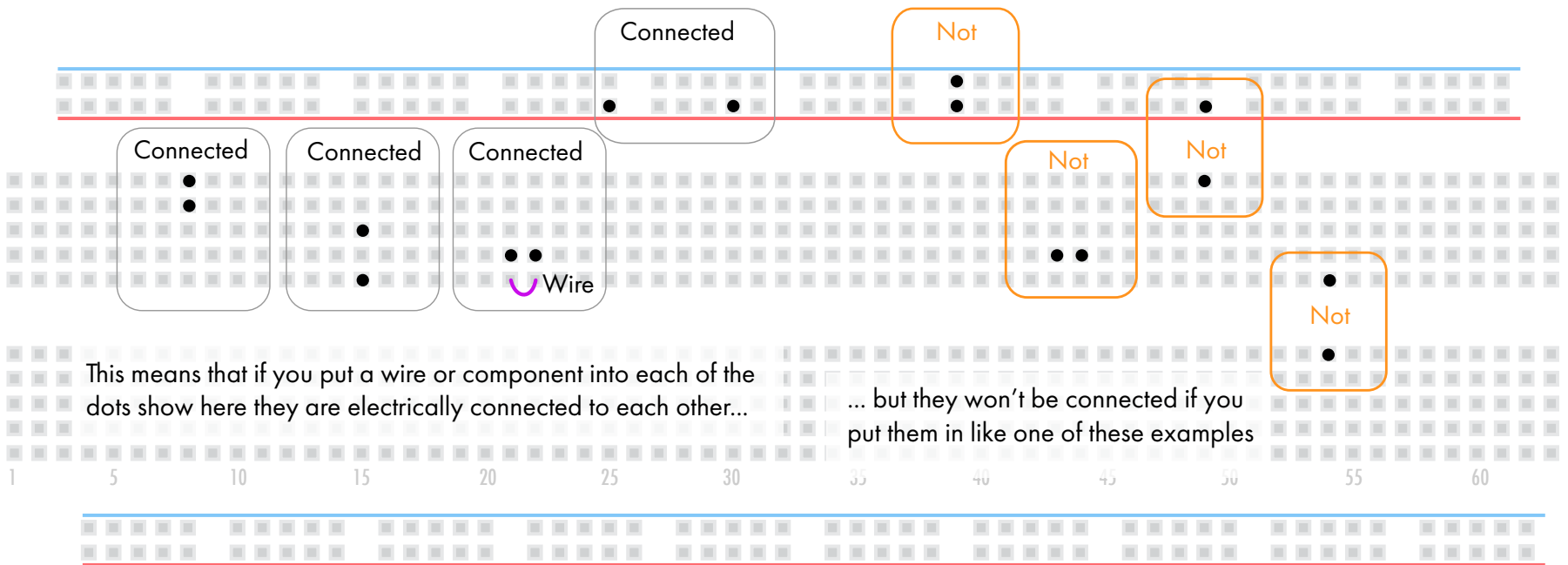

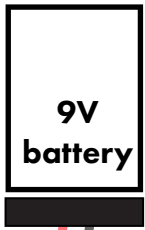

9V  
battery

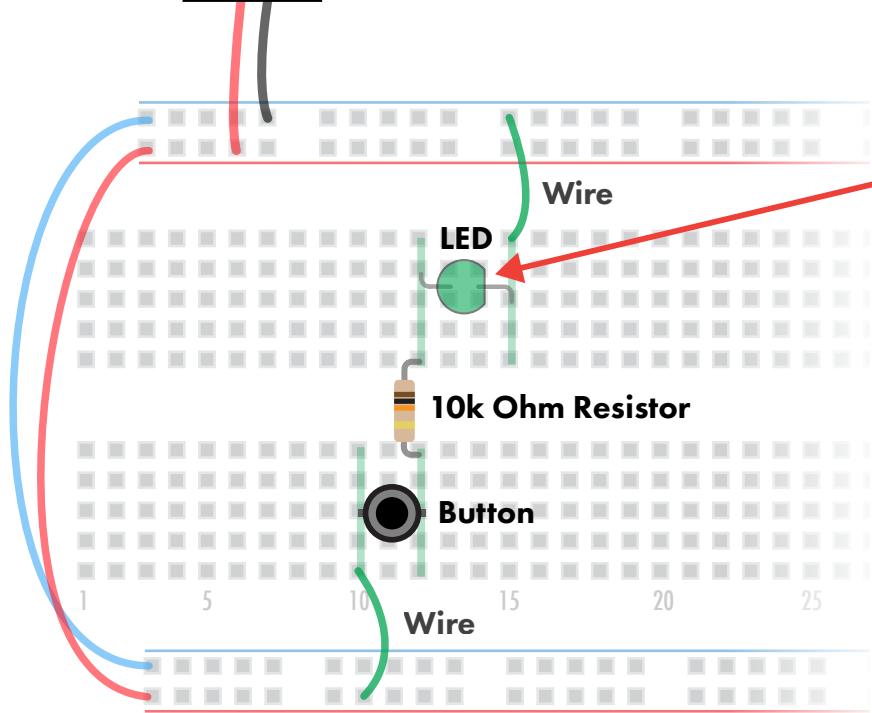

Wire

LED

10k Ohm Resistor

Button

Wire

## Let's make our first circuit!

Here we will use the button to turn the LED (Light Emitting Diode) on.

The button and resistor are non-polar meaning they can be put in either direction.

LEDs are polar, meaning they need to be installed in the circuit in the correct direction. Notice the notch on the right side of the LED. It corresponds to the notch on the LED itself. This "cathode" leg of the LED is shorter than the "anode" one.

When you push the button electricity can flow through the resistor to the LED. If the resistor was not there or if it was the wrong value there might be too much power for the LED and it would burn out.

Since we are just using a 9V battery we do not need to worry about being shocked. Take care to never "short out" the battery but directly connecting its two wires together. This will make the battery get hot and damage it.

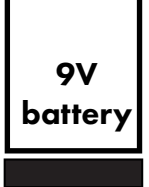

The same circuit can be built on the breadboard in many different ways.

